



Whiteriver Unified School District

Second Grade Packet

Week 1

Student Name:

School:

Teacher:

Reading
Week of May 4th 2020

Second Grade English Language Arts Learning Packet May 4th –May 22, 2020

Hello Parents,

This week's ELA Learning packet consists of two **TEXTS –The Butterfly Life cycle**-Non Fiction Text and **Butterfly Café**-Fiction Text. Students who are independent readers may read and complete the activities by themselves. If not, you may read the passages together and guide your child in completing each task. Make sure you have pencils, paper and coloring materials handy.

We have sent math sheets with the theme of Earth Day. Remember your strategies for regrouping. Practice your addition and subtraction 1-minute fluency challenge each day.

Remember, there are opportunities all around you every day to read and think with your math skills. Stay safe, and be kind, and count your blessings.

We miss all of you so much,

Your 2nd grade teachers.

My Choice Board

Choose #4 activities

to complete by _____ Date _____.

Get an egg carton cut it n half lengthwise and turn it over. It now looks like a caterpillar. Decorate it with crayons. Add sticks for antennas and little rocks for eyes. Be creative!

Ask your elders to tell you why the butterfly is one of the important clans in the Apache Culture.

Pretend you are a butterfly and write a story about being a butterfly in your journal. Draw and color a wonderful picture to go with the story.

Go to the website below to follow the monarch butterfly migration.
journeynorth.org >
[monarchs](#)
Write in your journal about what you learned.

Name: _____

©Brooke Brown



The Butterfly Life Cycle

A Reading A-Z Level K Leveled Book
Word Count: 425

LEVELED BOOK • K

The Butterfly Life Cycle

Connections

Writing and Art

Draw a diagram of the butterfly life cycle. Write about each stage and what happens in between the stages.

Science

Pick two stages of the butterfly life cycle. Compare and contrast them with a partner.



**Multi
Level
H•K•N**

Written by Torran Anderson

www.readinga-z.com

Reading A-Z

Visit www.readinga-z.com
for thousands of books and materials.

The Butterfly Life Cycle

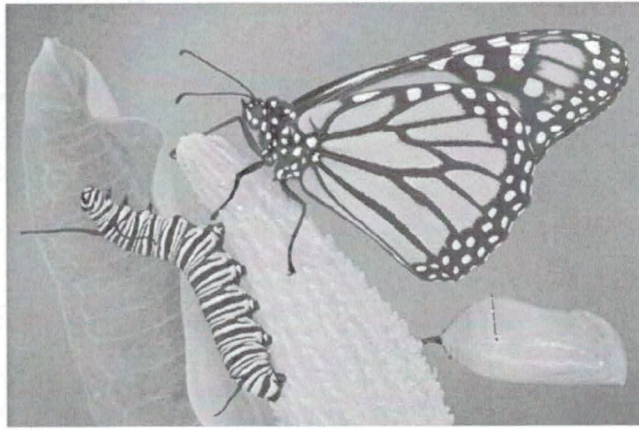

Written by Torran Anderson

www.readinga-z.com

Focus Question

What is the life cycle of a monarch butterfly?

Words to Know

butterfly pupa
life cycle scales
mate stages

Photo Credits:

Front cover, back cover: Kevin Knight/Alamy; title page: © iStock.com/Cathy Keifer; page 3 (main): © Roberta Olenick/All Canada Photos/Getty Images; pages 3 (inset), 6 (bottom): © Jordan McCullough/123RF; page 4 (top): © iStock.com/Steve Snyder; page 4 (center left, center right): © iStock.com/Susan Wood; page 4 (bottom): © iStock.com/Lisa Thornberg; page 5 (top main): © Leo Keeler/Auscape/The Image Works; page 5 (top inset): © Papilio/Alamy; pages 5 (bottom), 11 (bottom): © iStock.com/AmbientIdeas; page 6 (top): © Dick Poe/Visuals Unlimited, Inc.; page 7 (top): © Cathy Keifer/Dreamstime.com; page 7 (bottom): © Le Do/123RF; page 8: Blend Images/Alamy; page 9 (top left): © iStock.com/Joel Pogliano; page 9 (top right, center left, center right): Scott Camazine/Alamy; page 9 (bottom): © iStock.com/triggerrmouse; page 10: © Patty Jenks/Dreamstime.com; pages 11 (top left, top right, center left, center right), 12 (both), 13 (both): © Michael Durham/Visuals Unlimited, Inc.; page 14 (main): © iStock.com/Debra Wiseberg; page 14 (inset): © Ingo Arndt/Minden Pictures; page 15: © Jaap de Rooze

The Butterfly Life Cycle
Level K Leveled Book

© Learning A-Z

Written by Torran Anderson

All rights reserved.

www.readinga-z.com

Correlation

LEVEL K	
Fountas & Pinnell	J
Reading Recovery	17
DRA	18

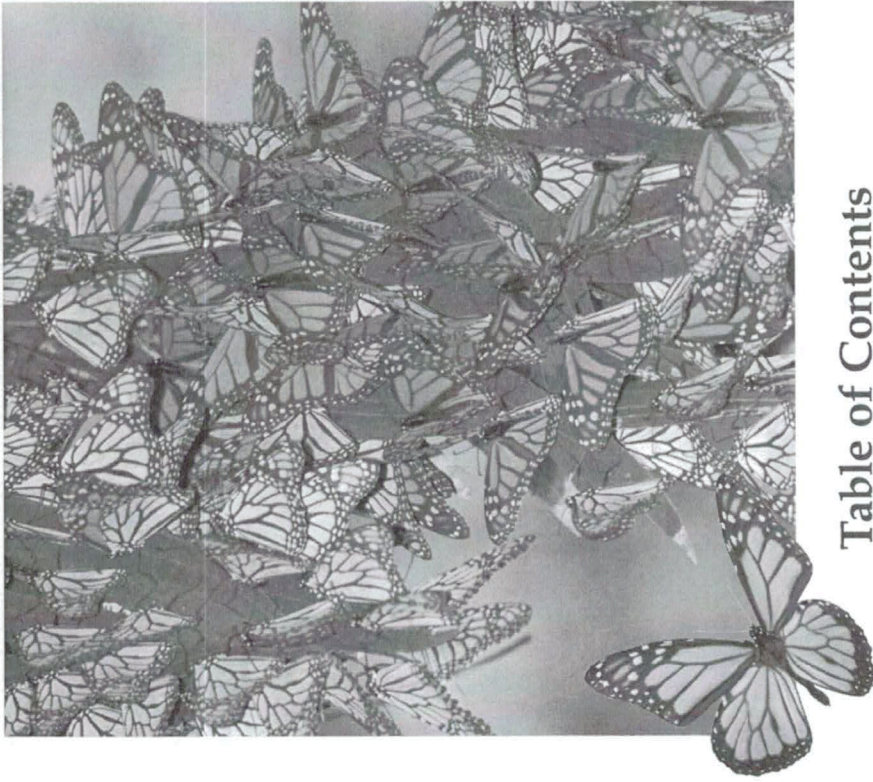
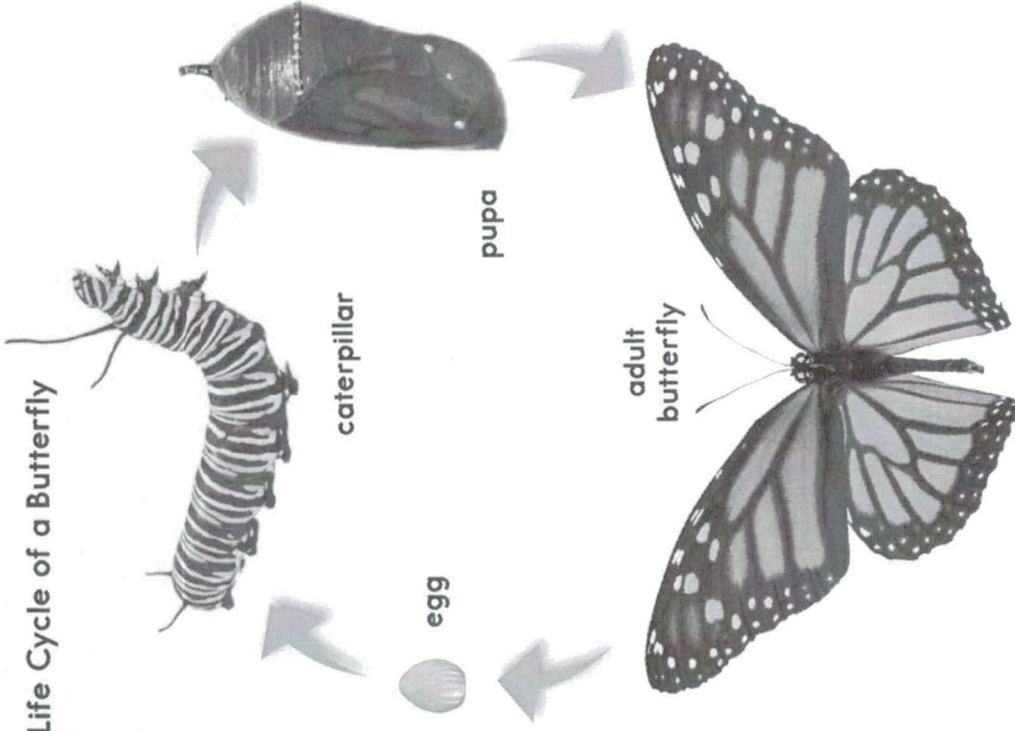

Table of Contents

The Life Cycle	4
Egg	5
Pupa	9
Adult Butterfly	11
Glossary	16

Life Cycle of a Butterfly



The Life Cycle

A monarch butterfly has four stages in its life cycle. They are egg, caterpillar, pupa, and adult.

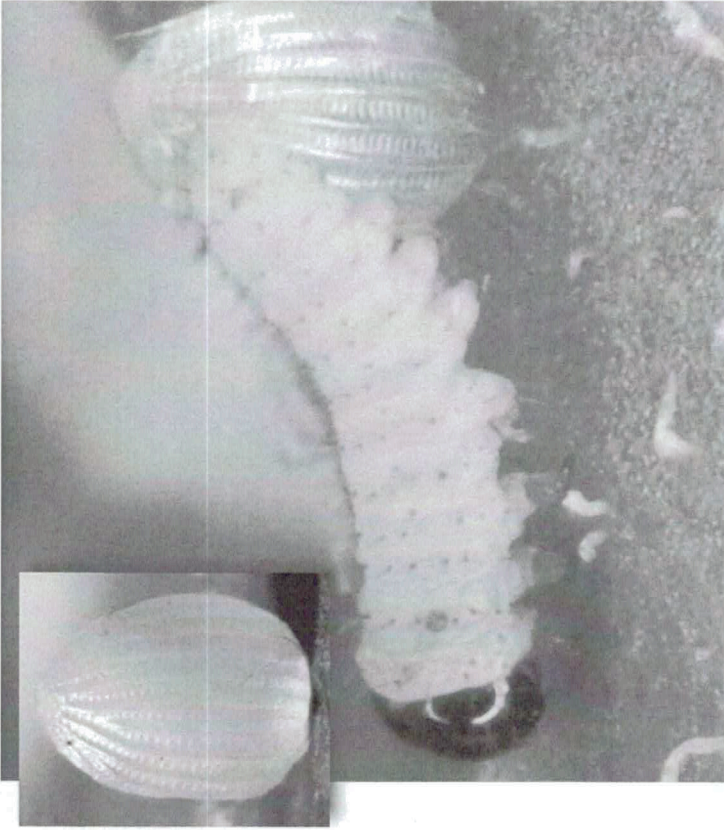

A young caterpillar hatches from its egg. A female monarch butterfly usually lays only one egg on a leaf.

Egg

A female monarch butterfly lays an egg on the bottom of a leaf. She might lay several hundred eggs in her lifetime. The eggs are oval shaped. A caterpillar grows inside the tiny egg. The egg hatches in three to twelve days.



The young caterpillar eats its own shell. If there are two eggs on a leaf, the caterpillar will eat the other egg first!

The hungry caterpillar eats all the time. It needs a lot of food to grow. First, the caterpillar eats its own eggshell. Then, the caterpillar eats the leaf it is on.



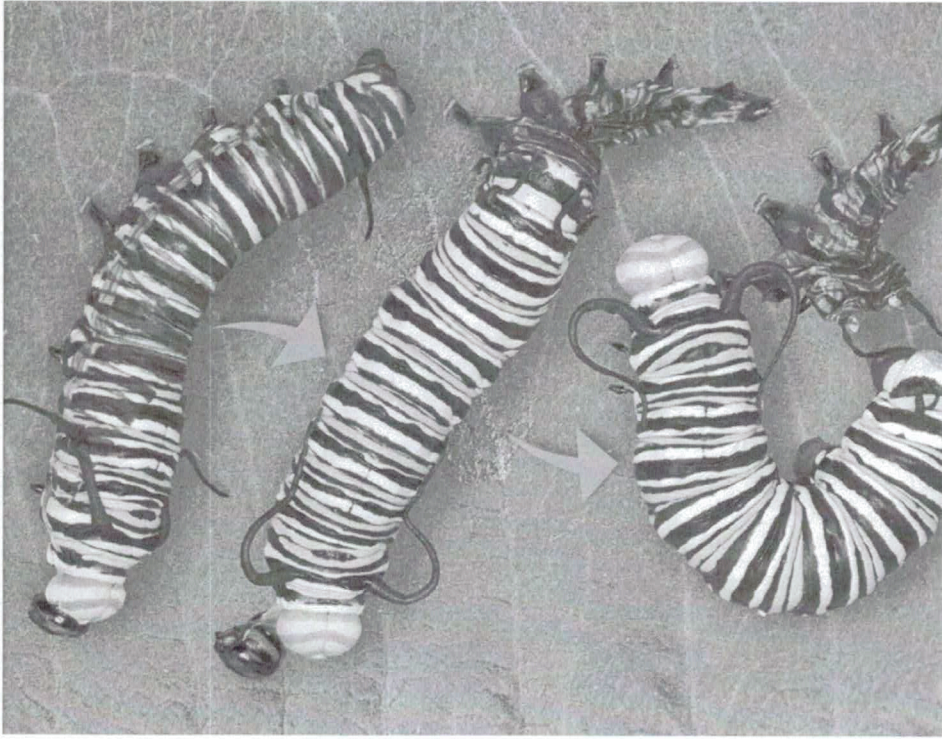

The caterpillar puts down sticky silk. The silk keeps the old skin in place while the caterpillar wiggles out of it.

The caterpillar grows quickly, but its skin does not grow. The caterpillar's old skin splits and peels away. The caterpillar will shed the old skin many times in this stage.



Do You Know?
Monarch caterpillars only eat the leaves of the milkweed plant.

The caterpillar's bright black and yellow colors warn animals that they will get sick if they eat it.

New skin is under the old skin. It is soft at first but soon hardens. The caterpillar sheds its skin four to six times and eats the old skin each time. The caterpillar grows for two to four weeks.

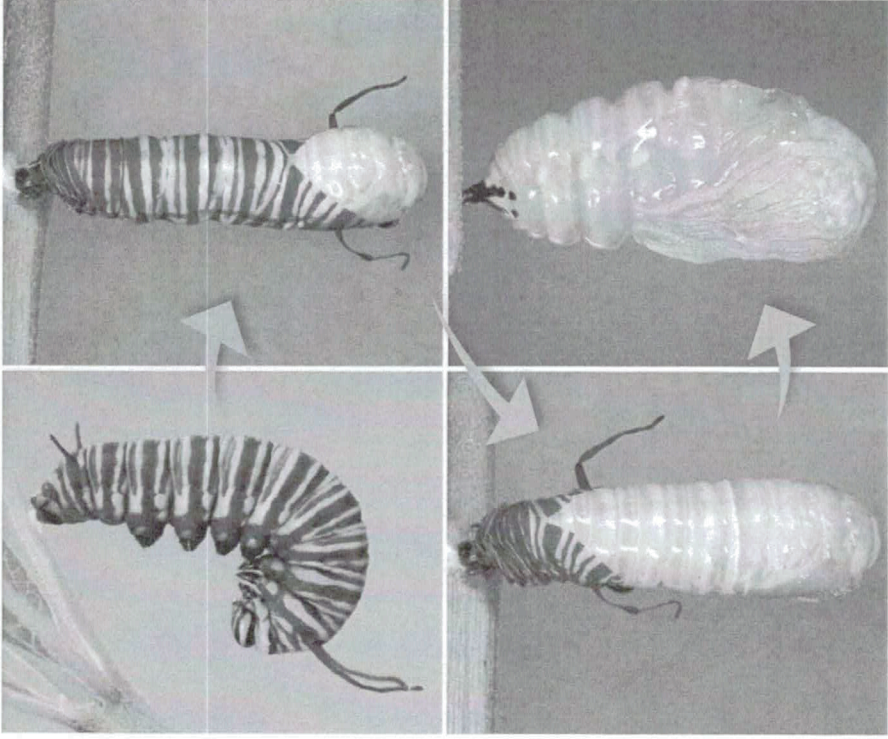

The caterpillar's skin splits down its back like a zipper!

Pupa

When the caterpillar is grown, it hangs from a branch to prepare for the next stage. It sheds its skin one last time. The new skin is bright green and looks like a leaf.

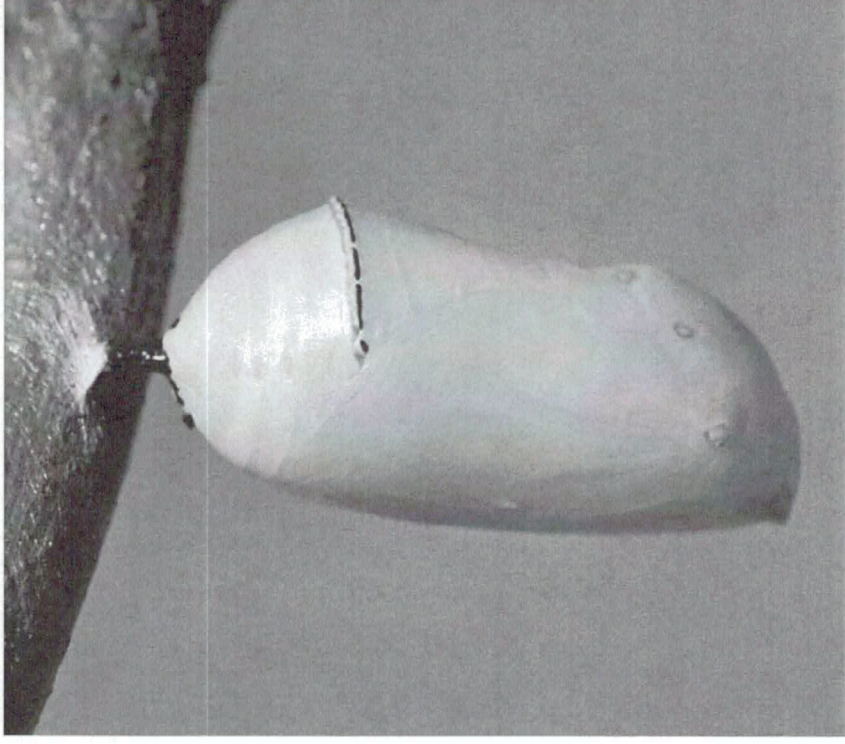

The green color helps the caterpillar hide from other animals.

This green skin hardens around the caterpillar. It will protect it from other animals as it changes inside. The caterpillar becomes a pupa. It will stay inside its shell for one to two weeks. During this time, big changes happen to its body.

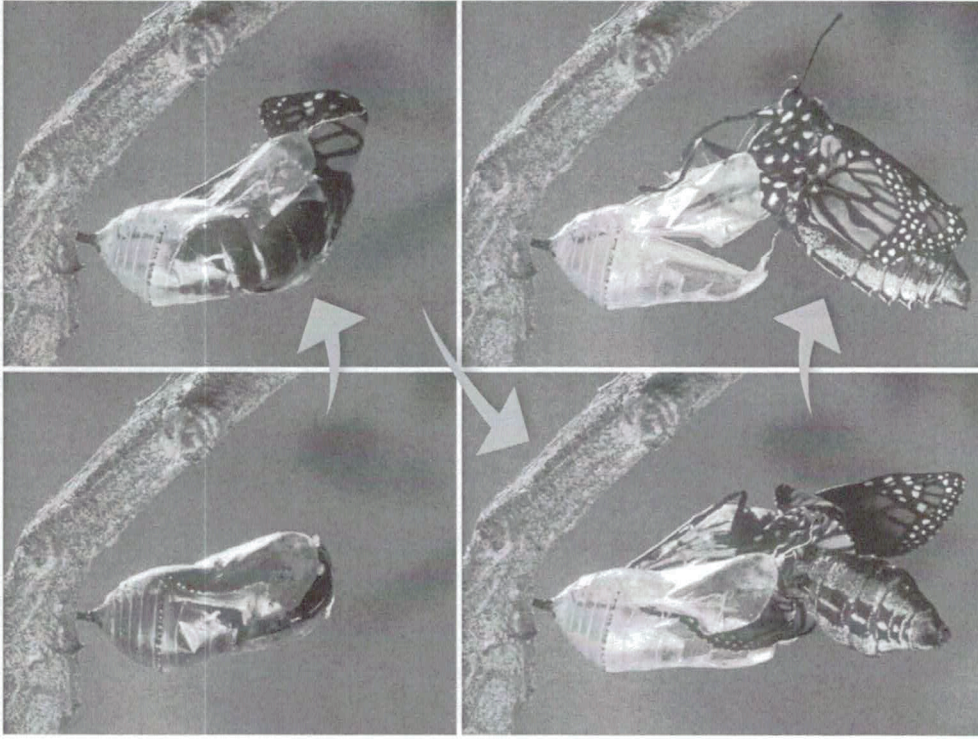

The butterfly breathes in air to make its body bigger. Then, the shell splits so the butterfly can climb out.

Adult Butterfly

An adult butterfly comes out of the shell. Its wet wings are folded against its body.

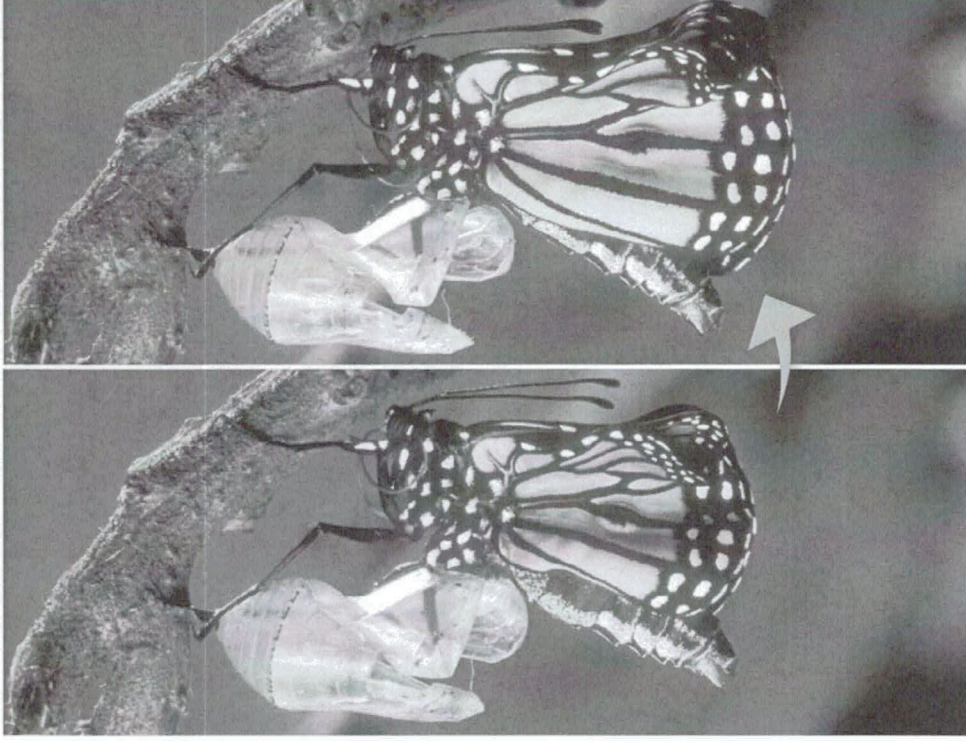

While the butterfly hangs, it pushes blood into its wings.

The new butterfly rests. The butterfly must hang upside down, or it will not be able to fly. Blood pumping into the wings causes them to unfold and spread out.

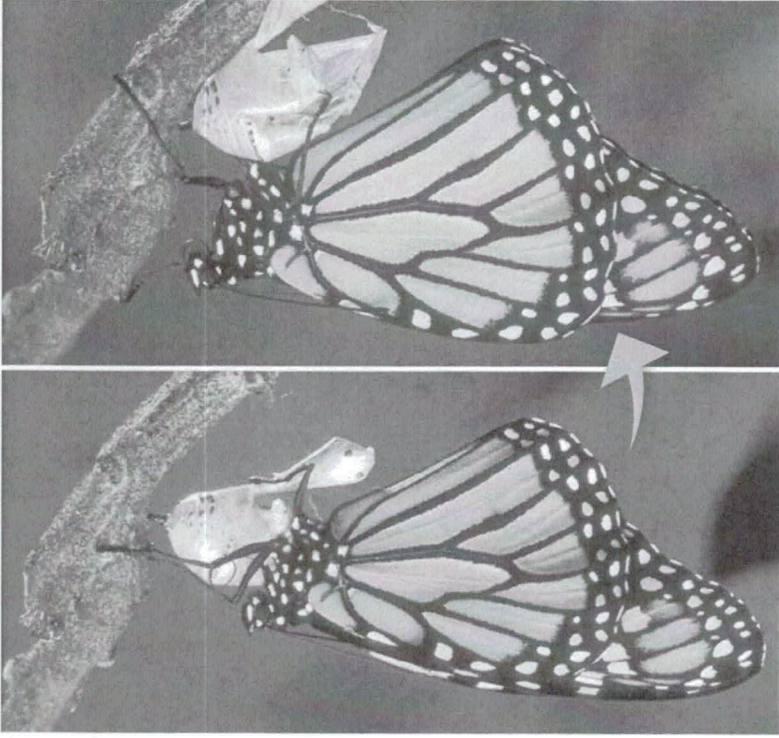

Most monarch butterfly wings are about 4 inches (10 cm) from tip to tip.

The butterfly hangs for several hours. The sun and air dry its delicate wings. A butterfly has two pairs of wings. They are covered in **scales**. The wings in the front often have a different pattern from the pair in the back. The colors on the wings are usually similar to each other.

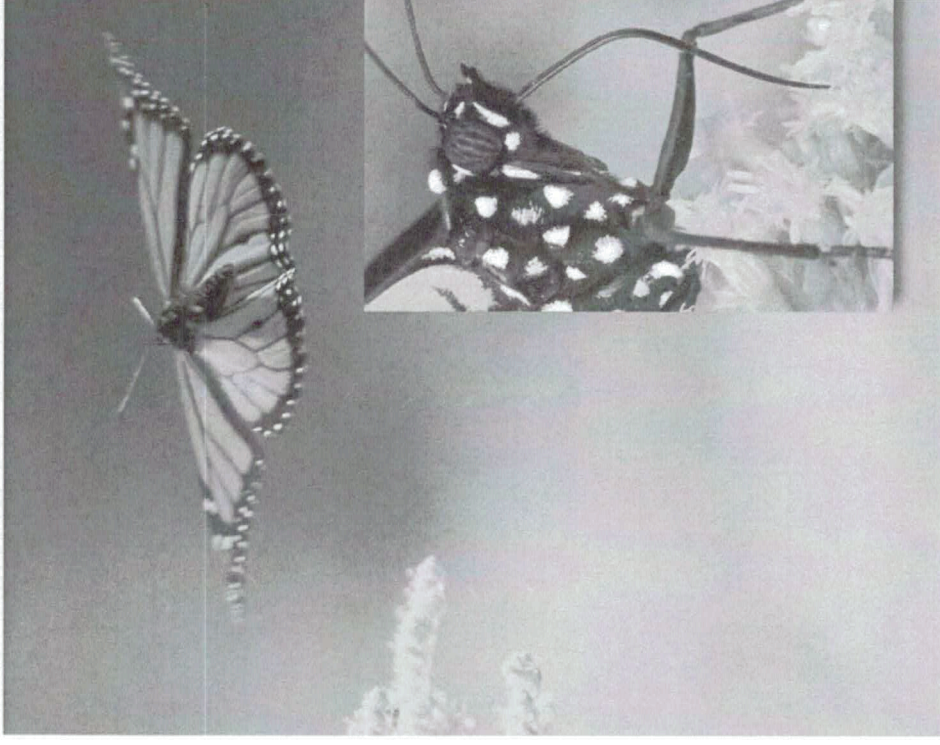

Monarch butterflies drink nectar, a sweet liquid made by plants, with a long tongue shaped like a tube.

Once the butterfly is able to fly, it flies off to eat. Unlike a caterpillar, a butterfly does not eat leaves. Instead, it sips sweet liquid from flowers. It also searches for a **mate**.

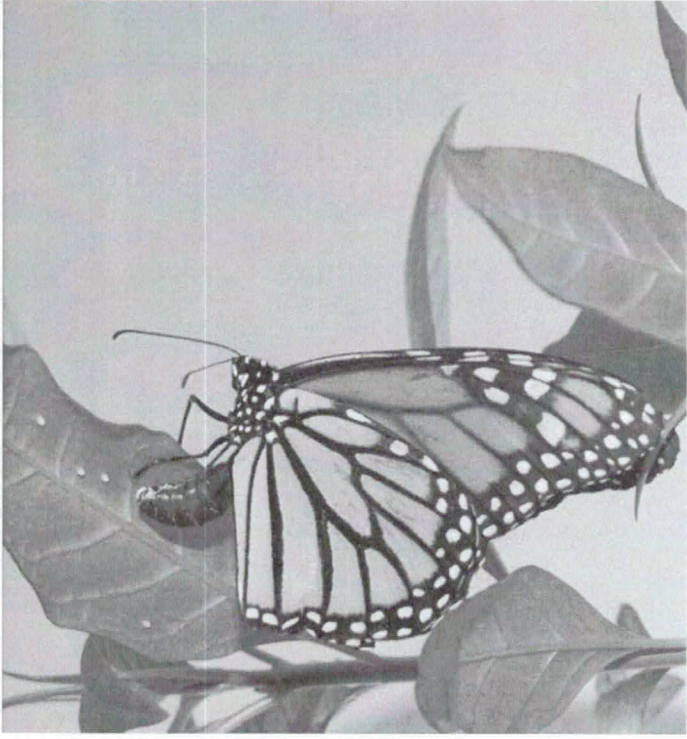

A female monarch butterfly may lay 400 to 500 eggs in her lifetime!

Adult butterflies do not grow. They save their energy for flying and laying eggs. Females are bigger than males.

A monarch butterfly may only live for two to six weeks. After she finds a mate, the female monarch lays her eggs. The butterfly life cycle starts all over again.

Glossary

butterfly (n.) an insect with four wings that are bright in color (p. 4)

life cycle (n.) the stages of change that a living thing goes through during its life (p. 4)

mate (n.) the partner of an animal with which it produces young (p. 14)

pupa (n.) a young insect in the stage between a larva and an adult (p. 4)

scales (n.) thin, flat plates that cover the outside of some animals (p. 13)

stages (n.) periods of time in the growth of something, such as insects (p. 4)

Name _____

Instructions: Write an event from the butterfly life cycle in each box. Be sure to list the events in the correct sequence.



1

2

3

4

5

6

7

8

Butterfly Café

A Reading A-Z Level H Leveled Book

Word Count: 180



Reading a-z

Visit www.readinga-z.com
for thousands of books and materials.

LEVELED BOOK • H

Butterfly Café



Written by Karen Mockler • Illustrated by Pamela Johnson

www.readinga-z.com



Our seeds came in the mail today.

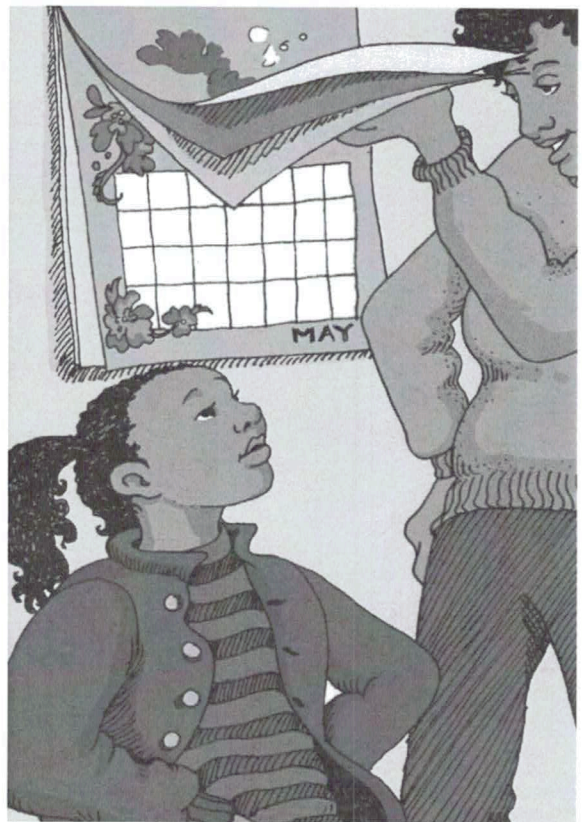

We could wait until May and plant them outside.
But May is three months away!

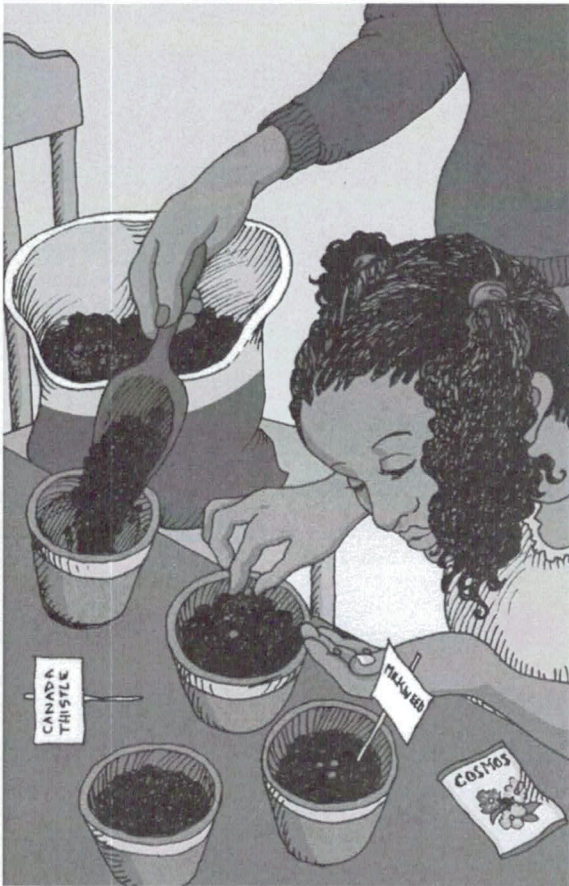

So we start our seeds inside.
We plant the seeds in pots of soil.



We water the pots at the kitchen sink.



We place the pots in a sunny window and we wait.

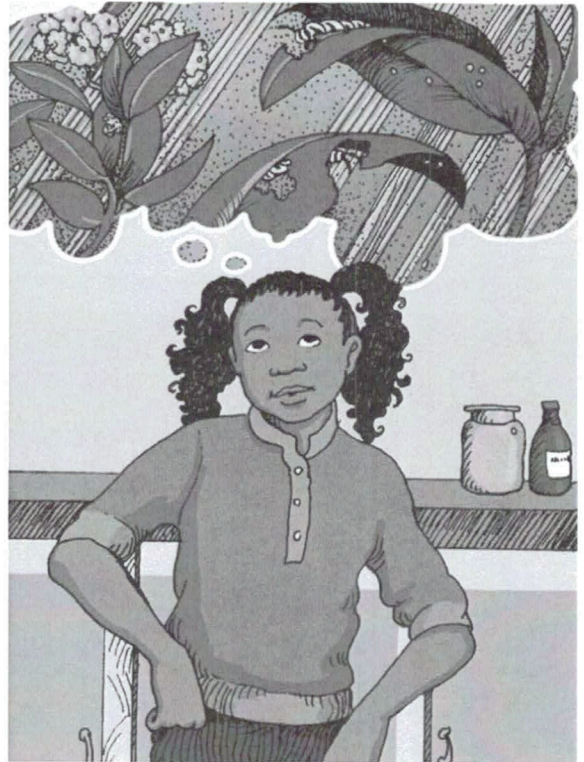

Some seeds will grow into food, but the food is not for us.

Some seeds will grow into **shelter**, but the shelter is not for us.

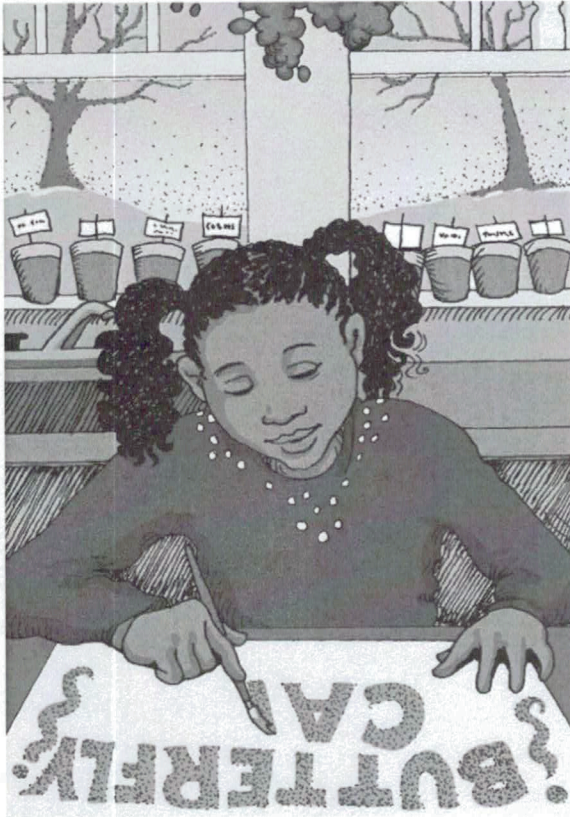

While we wait, I make a big sign.
I use orange and black paint.
The sign reads: Butterfly **Café**.



In early spring, the **sprouts** grow
into plants.



In late spring, we move the plants outside.



I place my sign beside the plants.
Butterfly Café is open.



I hope our **customers** will lay their eggs on the **milkweed** plants.
I hope our customers will eat the **nectar** from the food plants.

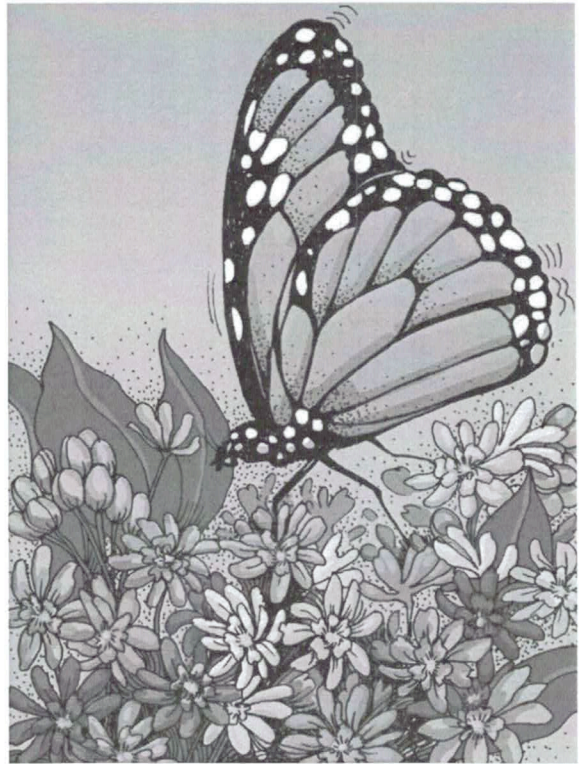

Our first customer arrives!
She is orange and black with white spots.
She is a **monarch** butterfly.

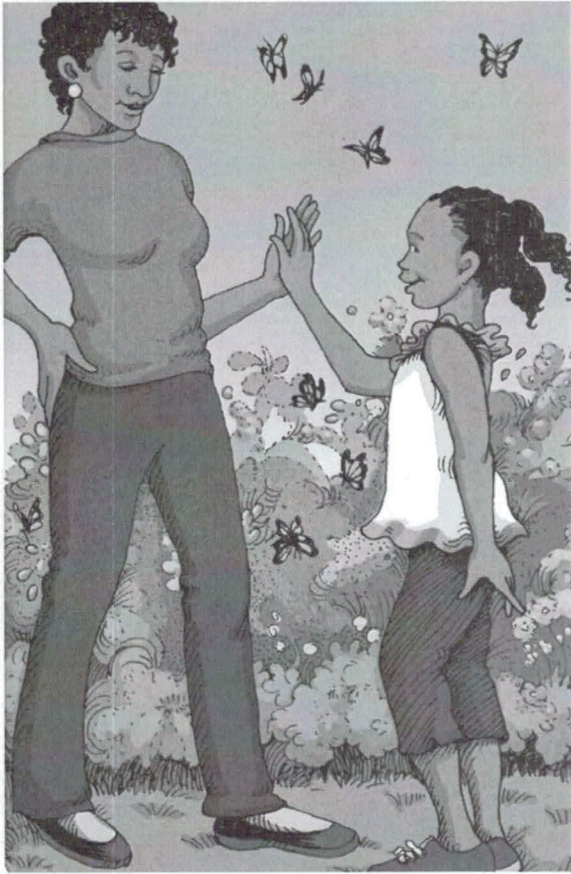

Soon our plants are full of butterflies.
Our café is a hit!

Glossary

- café** (*n.*) a small restaurant that sells drinks and light meals (p. 9)
- customers** (*n.*) buyers of a product or service (p. 13)
- milkweed** (*n.*) a type of plant with milky juice (p. 13)
- monarch** (*n.*) a large, colorful butterfly found in North America (p. 14)
- nectar** (*n.*) the sweet liquid that flowering plants make (p. 13)
- shelter** (*n.*) a structure or other place that gives protection from bad weather or danger (p. 8)
- sprouts** (*n.*) young plant growth (p. 10)

Name _____



Instructions: Have students cut out the pictures and paste them on a separate sheet of paper according to the sequence of events in the story. Then have them write a sentence about the event under each picture.

Name: _____

Write the answer for each problem. Then, color according to the key at the bottom.

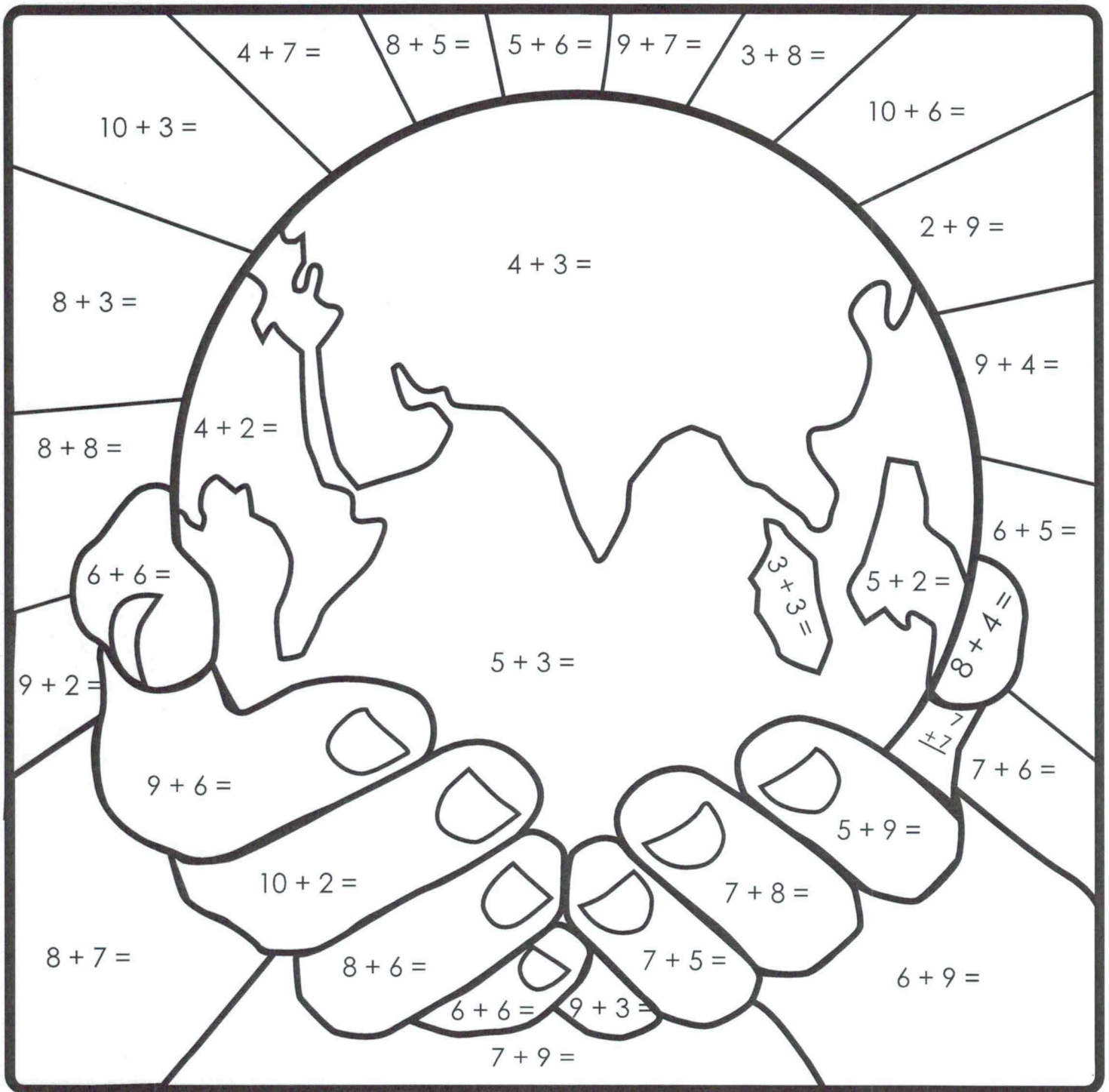

Orange 11

Blue 8

Yellow 16, 13

Green 6, 7

Skin Color 15, 14, 12

Name: _____

Add.

a.
$$\begin{array}{r} 307 \\ + 665 \\ \hline \end{array}$$

b.
$$\begin{array}{r} 551 \\ + 289 \\ \hline \end{array}$$



c.
$$\begin{array}{r} 906 \\ + 41 \\ \hline \end{array}$$



d.
$$\begin{array}{r} 204 \\ + 438 \\ \hline \end{array}$$

e.
$$\begin{array}{r} 174 \\ + 158 \\ \hline \end{array}$$

Re-write the problems vertically, then solve.

f. $123 + 456 = \underline{\hspace{2cm}}$

g. $109 + 297 = \underline{\hspace{2cm}}$

h. $645 + 88 = \underline{\hspace{2cm}}$

i. $82 + 682 = \underline{\hspace{2cm}}$

- j. To celebrate Earth Day, Mr. Ronn's class made Earth Day hats from recycled paper. The girls made 319 hats. The boys made 153 hats. How many hats did they make in all?

Remember to show your work and label your answer.

answer: _____

Name: _____

Subtract.

a.
$$\begin{array}{r} 371 \\ - 245 \\ \hline \end{array}$$

b.
$$\begin{array}{r} 952 \\ - 109 \\ \hline \end{array}$$



c.
$$\begin{array}{r} 206 \\ - 41 \\ \hline \end{array}$$

d.
$$\begin{array}{r} 873 \\ - 439 \\ \hline \end{array}$$

e.
$$\begin{array}{r} 475 \\ - 258 \\ \hline \end{array}$$

Re-write the problems vertically, then solve.

f. $223 - 127 = \underline{\hspace{2cm}}$

g. $889 - 60 = \underline{\hspace{2cm}}$

h. $115 - 61 = \underline{\hspace{2cm}}$

- i. To celebrate Earth Day, Mr. Johnson's class is planting small trees in a nearby park. The girls planted 102 trees. The boys planted 81. How many more trees did the girls plant?

Remember to show your work and label your answer.

answer: _____

Name: _____

Write the answer for each problem. Then, color according to the key at the bottom.

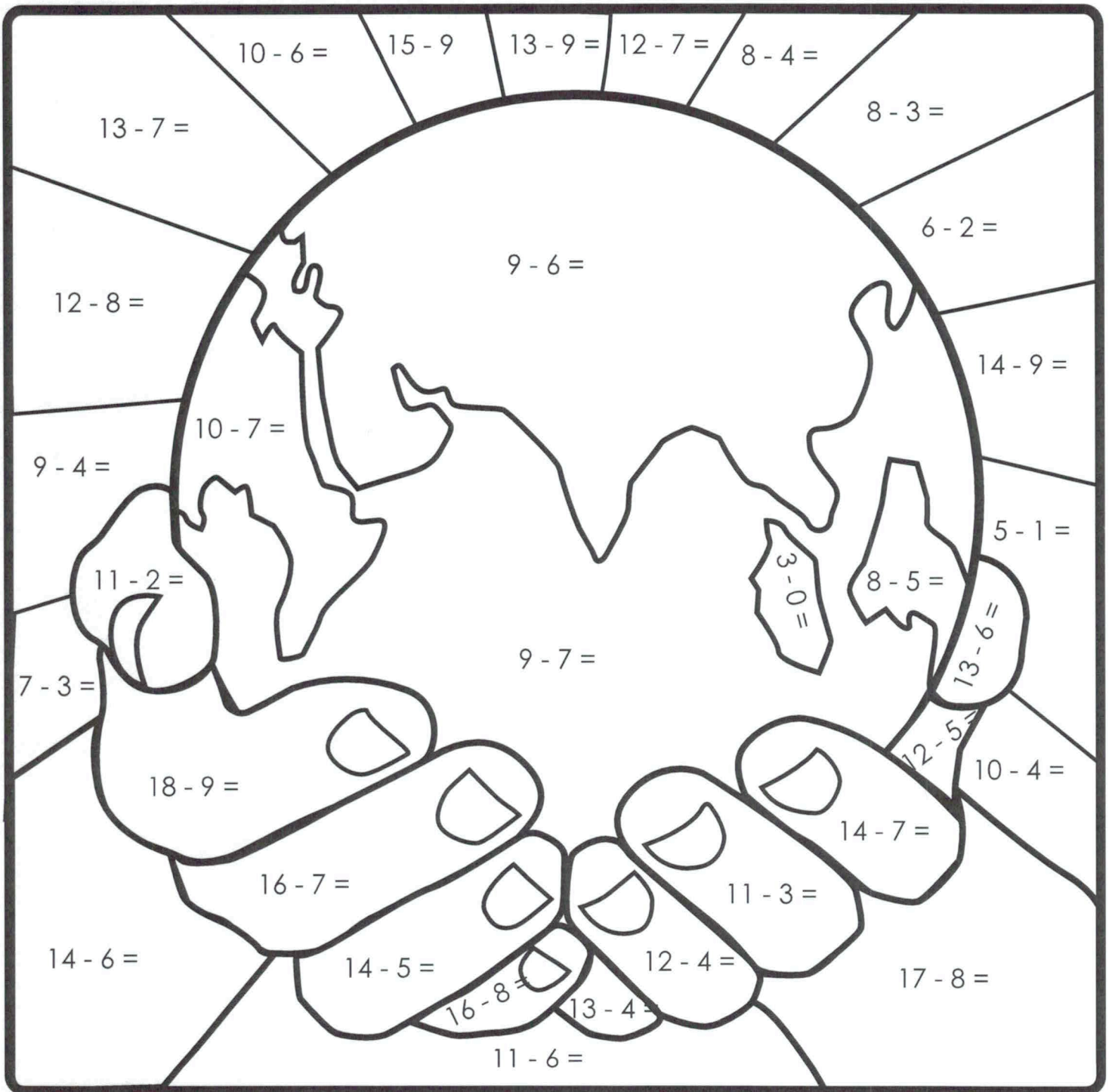

Orange 4

Blue 2

Yellow 6, 5

Green 3

Skin Color 9, 8, 7

Read the poems and then try writing your own poem.

The Fuzzy Caterpillar

(to the tune of "The Eensy Weensy Spider")

The fuzzy caterpillar
Curled upon a leaf,
Spun her little chrysalis
And then fell asleep.
While she was sleeping,
She dreamed that she could fly,
And later when she woke up
She was a butterfly!

Caterpillar

Creepy crawly caterpillar
Looping up and down,
Furry tufts of hair along
Your back of golden brown.

You will soon be wrapped in silk,
Asleep for many a day;
And then, a handsome butterfly,
You'll stretch and fly away.

Mary Dawson

Take a 1 minute test every day!



Final Assessment Test



Day
①

	②	③	④	⑤					
$\frac{16}{-9}$	$\frac{10}{-8}$	$\frac{9}{-7}$	$\frac{8}{-4}$	$\frac{6}{-3}$	$\frac{6}{-2}$	$\frac{4}{-1}$	$\frac{0}{-0}$	$\frac{5}{-0}$	$\frac{8}{-0}$
$\frac{14}{-6}$	$\frac{11}{-9}$	$\frac{9}{-8}$	$\frac{11}{-7}$	$\frac{9}{-4}$	$\frac{7}{-3}$	$\frac{8}{-2}$	$\frac{5}{-1}$	$\frac{1}{-0}$	$\frac{6}{-0}$
$\frac{5}{-5}$	$\frac{15}{-6}$	$\frac{12}{-9}$	$\frac{17}{-8}$	$\frac{12}{-7}$	$\frac{10}{-4}$	$\frac{8}{-3}$	$\frac{7}{-2}$	$\frac{6}{-1}$	$\frac{2}{-0}$
$\frac{15}{-7}$	$\frac{6}{-5}$	$\frac{14}{-6}$	$\frac{13}{-9}$	$\frac{16}{-8}$	$\frac{13}{-7}$	$\frac{11}{-4}$	$\frac{9}{-3}$	$\frac{9}{-2}$	$\frac{7}{-1}$
$\frac{18}{-8}$	$\frac{13}{-7}$	$\frac{7}{-5}$	$\frac{13}{-6}$	$\frac{14}{-9}$	$\frac{15}{-8}$	$\frac{14}{-7}$	$\frac{12}{-4}$	$\frac{11}{-3}$	$\frac{10}{-2}$
$\frac{4}{-4}$	$\frac{14}{-8}$	$\frac{14}{-7}$	$\frac{8}{-5}$	$\frac{12}{-6}$	$\frac{15}{-9}$	$\frac{14}{-8}$	$\frac{15}{-7}$	$\frac{13}{-4}$	$\frac{12}{-3}$
$\frac{13}{-3}$	$\frac{5}{-4}$	$\frac{15}{-8}$	$\frac{15}{-7}$	$\frac{9}{-5}$	$\frac{11}{-6}$	$\frac{16}{-9}$	$\frac{13}{-8}$	$\frac{16}{-7}$	$\frac{14}{-4}$
$\frac{2}{-2}$	$\frac{4}{-3}$	$\frac{6}{-4}$	$\frac{16}{-8}$	$\frac{16}{-7}$	$\frac{14}{-5}$	$\frac{10}{-6}$	$\frac{17}{-9}$	$\frac{12}{-8}$	$\frac{17}{-7}$
$\frac{13}{-10}$	$\frac{3}{-2}$	$\frac{5}{-3}$	$\frac{7}{-4}$	$\frac{17}{-8}$	$\frac{7}{-7}$	$\frac{13}{-5}$	$\frac{9}{-6}$	$\frac{18}{-9}$	$\frac{11}{-8}$
$\frac{11}{-10}$	$\frac{17}{-10}$	$\frac{4}{-2}$	$\frac{6}{-3}$	$\frac{8}{-4}$	$\frac{9}{-8}$	$\frac{8}{-7}$	$\frac{12}{-5}$	$\frac{8}{-6}$	$\frac{19}{-9}$

Today's Number: 632

Odd or Even

Write in Word Form: _____

Place Value: _____ hundreds, _____ tens, _____ ones

Draw It:

Hundreds	Tens	Ones

Expanded Form: _____ + _____ + _____

$$+10 = \underline{\hspace{2cm}}$$

$$+100 = \underline{\hspace{2cm}}$$

$$-10 = \underline{\hspace{2cm}}$$

$$-100 = \underline{\hspace{2cm}}$$

Today's Numbers: 349 and 154

1. Compare them. $>$ $<$ \equiv

Always put the
larger number on
TOP ☺

2. Add them.

$$\begin{array}{r} + \\ \hline \end{array}$$

3. Subtract them.

$$\begin{array}{r} - \\ \hline \end{array}$$

Today's Number: 547

Odd or Even

Write in Word Form: _____

Place Value: _____ hundreds, _____ tens, _____ ones

Draw It:

Hundreds	Tens	Ones

Expanded Form: _____ + _____ + _____

+10 = _____ +100 = _____

-10 = _____ -100 = _____

Today's Numbers: 328 and 243

1. Compare them. $>$ $<$ \equiv

Always put the
larger number on
TOP ☺

2. Add them.

$$+ \quad \underline{\hspace{2cm}}$$

3. Subtract them.

$$- \quad \underline{\hspace{2cm}}$$

APACHE LANGUAGE LESSON PLAN

Teacher: M. Alsenay

The month of MAY 2020

Materials needed: blank whiter paper or lined paper and crayons

5th-3rd grade

2nd-Kindergarten

Spiral: Phrases and words say everyday by student as much as they can remember is sufficient

Da'gote-(how are you)? **Da'gostig**-(I am okay). **Shii' Indee is'shlee shil nzhoo**-(I love being Apache).
In Apache Language-The Pledge of Allegiance (hanging up by the flag).
Body Parts in Apache, Counting in Apache, Colors in Apache, Days of the Week in Apache,

LEARNING GOAL: Students will learn and/or demonstrate their mastery of the Apache Language lesson by reading, speaking, writing, or listening via vocabulary words, and/or phrases rehearsed:
Students should be able to read the following story and vocabulary words for a Mother's Day Card.

Mother's Day phrases for a card:

Shi' Maa-My Mother

Shi'maa shil nzhoo-I love My Mother

Shi'da'silijj yé sha'aile'-She feeds me when I am hungry, **Shi'diyage aldo shá áyile'**-She provides my clothes,

Shi'Maa denzhoone'-my mother is beautiful

Shil Nzhoo Shi'maa-I Love You Mom

I DO/ADULT:

I will demonstrate how to read the story in Apache Language and in English.

I will demonstrate the pronunciation of each Apache Language phrase for the Mother's Day card

YOU DO TOGETHER: Say each word together and/or with other siblings at home.

I will demonstrate how to read the story in Apache Language and in English.

I will demonstrate the pronunciation of each Apache Language phrase for the Mother's Day card

I Do (Independent)

Student will color the picture and sign the card with their name.

On a separate piece of paper or lined paper the student will write the mother's day phrases in the Apache Language (use what is available at home).

Parents/Guardians: please use these words while at home as much as possible. Or pick a certain time of day to have the child repeat the words or phrases to you, sibling, or grandparent. So they can keep up and not loose what we have learned this year.

End of the lesson ask the student: Two ways to say *Thank-you in Apache Language?*

And How do you say: *See you later in Apache Language?*

Review words:

Yaa-sky

Yaak'os-clouds,

Dzil Ligai Si'an-White Mountain

Zas-snow

tunlii-river

dzil K'ee-aspen tree

Dilchi-pine tree

gad-cedar tree

t'iis-cottonwood tree

Gowa-wickiup

kih-house

tal'toh-ramada

Shiima Ch'ich'it Nayilaa

Mother Gets Acorn

Shiima ta' íí bit'éké nzaagyú
onat'ash chich'il nadayilago tats' aa'
yiyi hadayidibjh. Chich' il gał
nahásdllaago nt'éégo alde', hik'aa
áíye' hilzhó áíkédégo hik'azhgo
hik'aa. Isaa' biyi' chich'il hi it'ch'í'
nijah gonezk'azyu sine'go, áíye'
dak'íí hachit'í'ye hanáchijii.
Ch'ich'it hí, itoo' bit' nadigeed Ndee
Bi'idan at'éé'.

My mother and her friend traveled far to pick
acorns to fill the basket.
After the acorns have been picked,
They are cleaned, shelled and ground
very fine. The ground acorn is
stored in a cool place in a container,
ready to be used anytime. Acorns are Apache
food and are used to flavor stew.

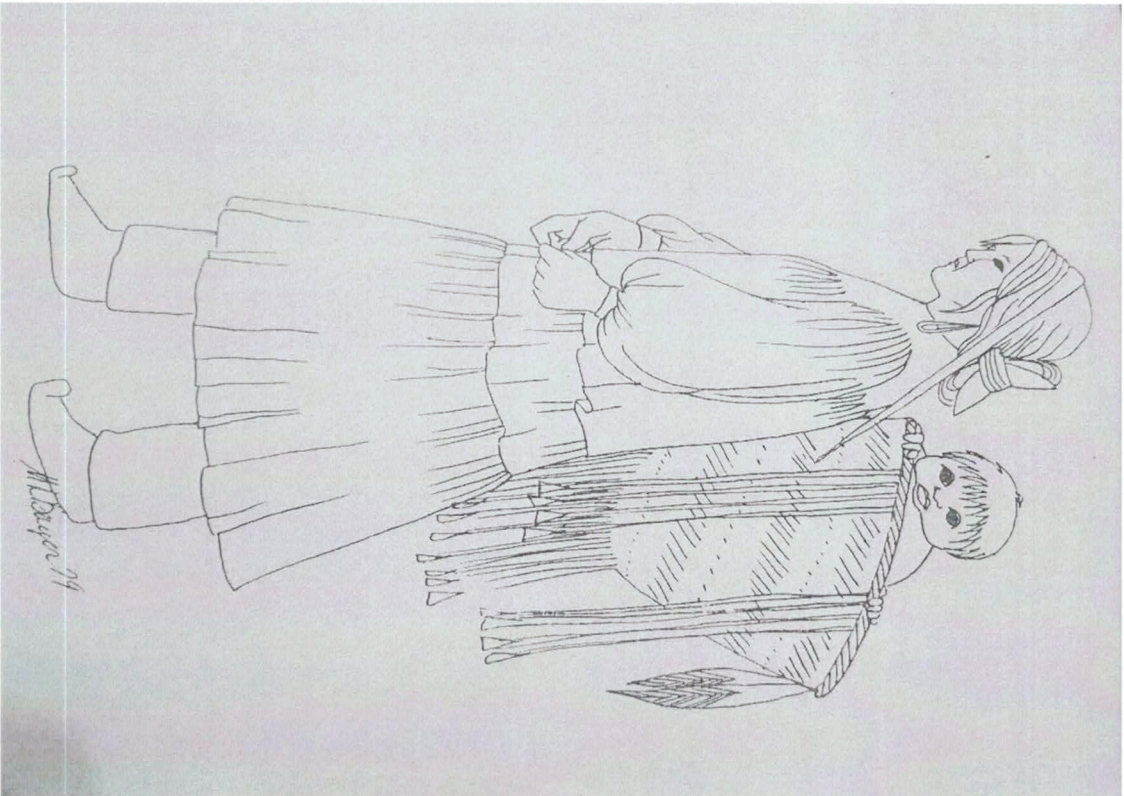

Shi'Maa (My Mother)

Shi'Maa

My Mother,

Shi'diyage' atdo shá ayile',

She provides my clothes,

Shi'maa

My Mother

Shi dá silijí ye' shá aile'

Feeds me when I'm hungry,

Shi'maa denzhoone'

My mother is beautiful

Shi'maa, shi' shít nzhoo

My Mother I love you,

Dear Parents/Guardians,

I'd like to thank you for your help in making sure our students remain creative during this time of school closures. Art is an important part of a child's growth, so it is great to know that they are continuing their art work at home. For this month of May, we have some artwork that has to do with summer activities as well as an opportunity to study another culture in a far away land. The projects for May require a specific set of materials that I hope you can help the students obtain. Having been closed for so long and with so many students, the Whiteriver Elementary School will need some assistance from you to ensure students acquire those materials. Some tools to keep on hand include scissors, markers, crayons, and glue. Construction paper and drawing paper are also always good to keep on hand. With this list of materials completed you can be sure that the children will have so much fun art to make. Once again, thank you for helping the students reach their academic and artistic goals from home.

Sincerely,

Mr. Rocky-WES Art Teacher

Secondary Grades Art lesson for May

Title: Marshmallows over fire

Materials: blue construction paper, brown construction paper orange construction paper, yellow construction paper, popsicle stick, 3 cotton balls, marker, scissors, glue.

Lesson: Summer is a time for fun activities we can do outside. One of my all-time favorite summer activities is roasting marshmallows. To celebrate the summer approaching we are going to make an art piece that represents roasting marshmallows.

Step 1: To roast marshmallows we need a fire and a fire needs wood, so begin by drawing a stack of wood on your brown paper and cut it out.

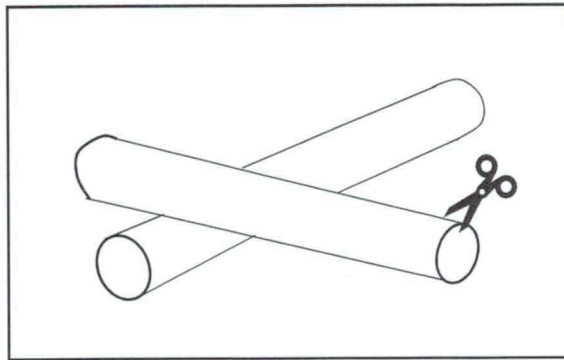

Step 2: Now we build the fire, so draw your flames on the yellow paper and the orange paper the cut them out.

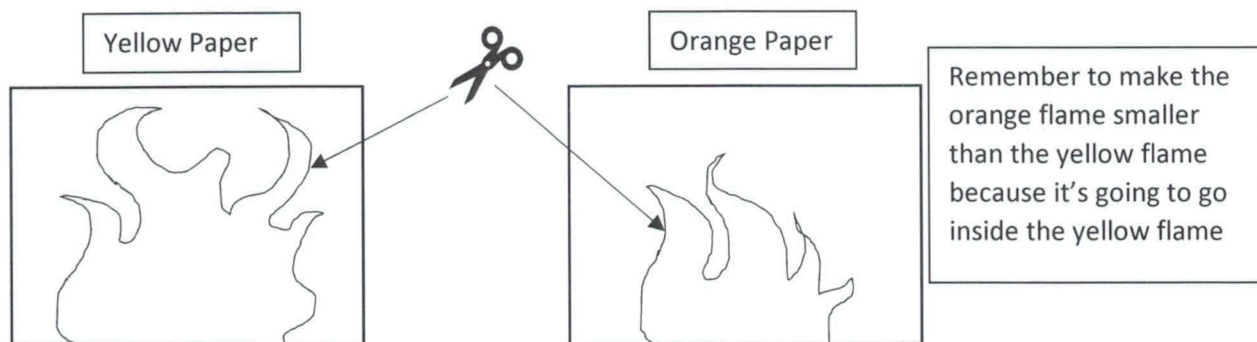

Step 3: Now we take our fire and wood and glue them to our blue paper to make a campfire.

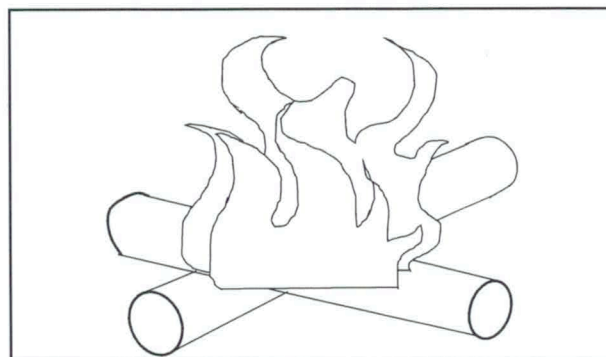

Step 4: All that is left now is the marshmallows on a skewer. Write your name on the popsicle stick then glue it with the cotton balls onto to blue paper to make the marshmallow stick.

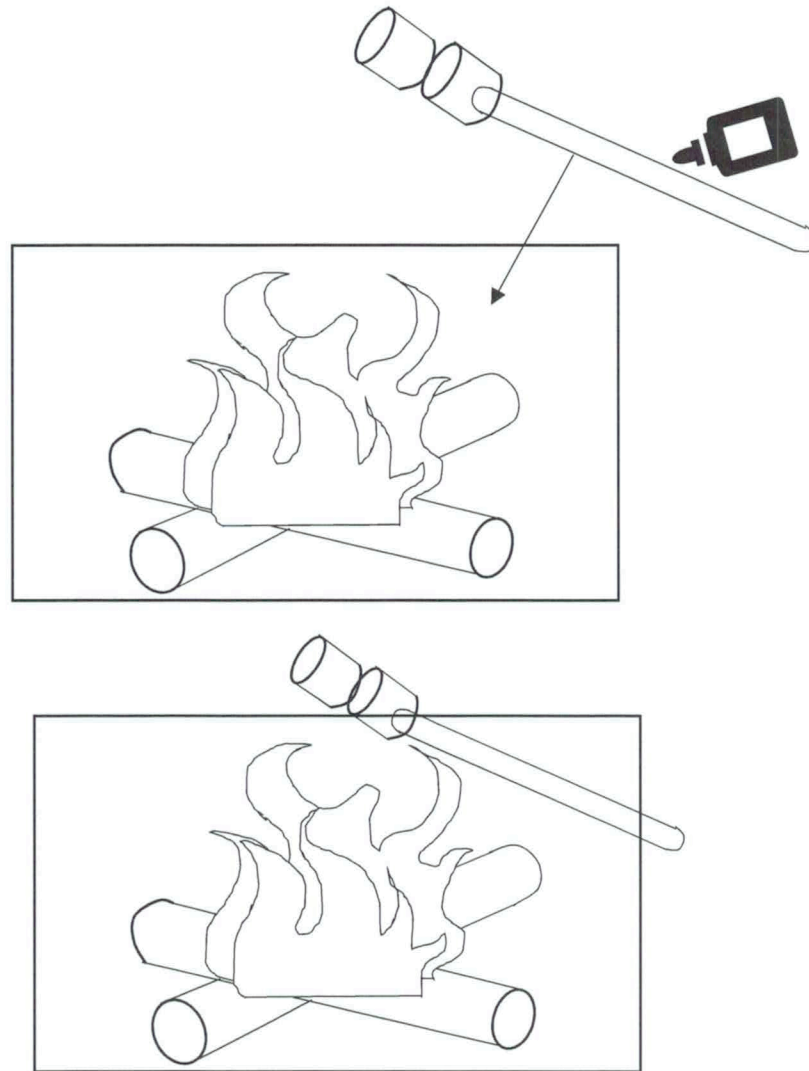

Congratulations! Great job on this summer art work. I hope your summer is full of fun activities like roasting marshmallows!

Hello WUSD Primary Students!

This is Mr. Taylor again. Here with some fun activities you can do from home. Spring is here and I hope you are going outside, staying in your yard and being safe and healthy. Have fun with these activities and be safe.

1. We are going to work on kicking a ball. I want you to find any ball, take it outside and kick it. Walk up, count your steps, and kick it as far as you can. I want you to kick the ball again and do the same thing, You need to count your steps a second time. Add up your steps you counted the first time with your steps you counted the second time. Kick it again and keep adding up your steps.
2. I want to get the same ball again and set up two rocks about 3 feet apart. Take about 10 steps back and try to kick the ball between the rocks. You can do this a number of times adding up how many times you can kick the ball between the rocks.
3. Please see the following worksheet for the next activity. Spell your name and use the activity sheet. You may spell others names. You can spell out any word you want to.
4. Find different kinds of pots or pans and one or two sticks. If you have some music, turn it on and bang the pots or pans with the sticks to the rhythm of the music. If you do not have music, make up your own rhythms. You might want to do this outside because you might drive your parents nuts.
5. Play simon says with your family. You can play with your older brother, sister or parent who will need to read the words for you. If you say "Simon says" then the other family members have to do what you say. If you don't say "Simon says" then they do not do what you say.

SUPER FUN EXERCISES FOR KIDS

Fit activity for kids what's your name?

SPELL OUT YOUR FULL NAME AND COMPLETE THE ACTIVITY LISTED FOR EACH LETTER. FOR A GREATER CHALLENGE INCLUDE YOUR MIDDLE NAME & DO EACH ONE TWICE! FOR VARIETY YOU CAN USE A FAVORITE CHARACTER'S NAME OR A FAMILY MEMBER'S NAME.

- | | |
|---|--|
| A jump up & down 10 times | N pick up a ball without using your hands |
| B spin around in a circle 5 times | O walk backwards 50 steps and skip back |
| C hop on one foot 5 times | P walk sideways 20 steps and hop back |
| D run to the nearest door and run back | Q crawl like a crab for a count of 10 |
| E walk like a bear for a count of 5 | R walk like a bear for a count of 5 |
| F do 3 cartwheels | S bend down and touch your toes 20 times |
| G do 10 jumping jacks | T pretend to pedal a bike with your hands for a count of 17 |
| H hop like a frog 8 times | U roll a ball using only your head |
| I balance on your left foot for a count of 10 | V flap your arms like a bird 25 times |
| J balance on your right foot for a count of 10 | W pretend to ride a horse for a count of 15 |
| K march like a toy soldier for a count of 12 | X try and touch the clouds for a count of 15 |
| L pretend to jump rope for a count of 20 | Y walk on your knees for a count of 10 |
| M do 3 somersaults | Z do 10 push-ups |



Whiteriver Unified School District

Second Grade Packet

Week 2

Student Name:

School:

Teacher:
